

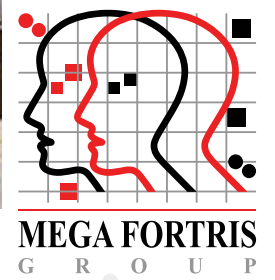

This product available in biodegradable alternatives.



Indicative Seal · Data Sheet

Mega Spinner

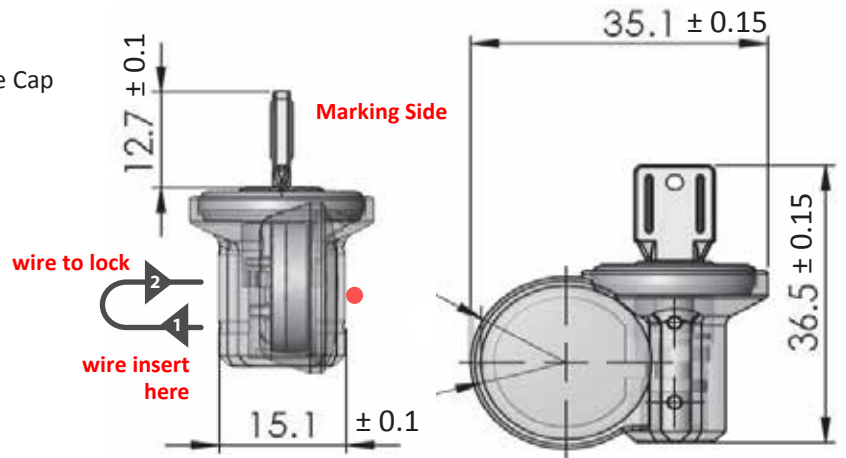
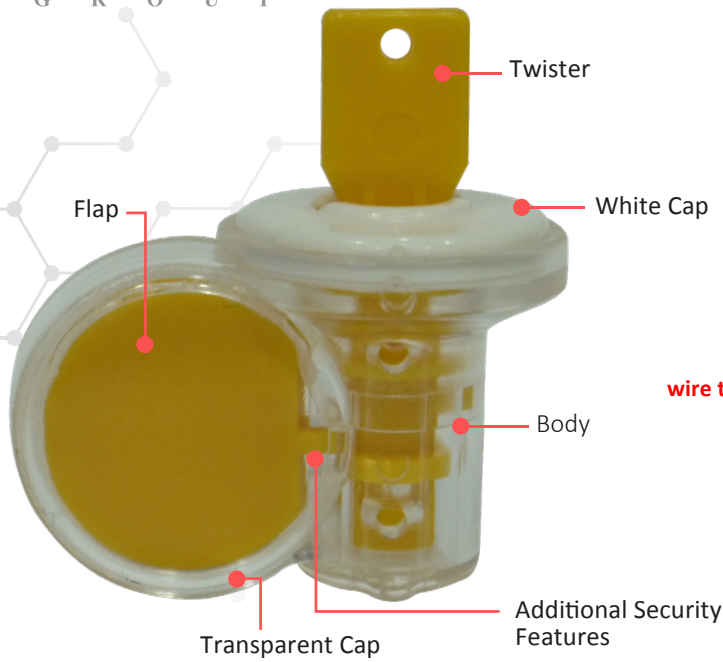

Features

- 1 The mega Spinner seal is laser print direct thru to the transparent cap and etched permanently. Laser marking offers the highest level of security as it cannot be removed and replaced.
- 2 The marking provides permanent etching for serial number, barcode, logo and text, whichever able accommodate within the perimeter of the marking flap.
- 3 The mega Spinner marking flap comes an optional colour white & yellow.
- 4 Additional security features added in the design of the marking flap to preventing tampering the twister.
- 5 Laser marking accommodate 1D & 2D, BC. The Transparent and white capping ultrasonic welding to provide strong bonding to prevent easy tampering.
- 6 Optional- **Biodegradable** additive can be added upon customers' requirement, securing strap gives the user a choice of strength to match different applications.

Technical Specifications

PRODUCT - MEGA SPINNER

Code	Material	Locking Length	Wire Dimensions	Tensile Strength	Marking Area	Max Marking Digits
MS	Body : PMMA Body Cap : PMMA Insert : Acetal Flap A : PP Flap B : PP Cap : ABS HI	Standard : 250 mm (9.84 in)	SS (Coated) 0.8 mm (0.031 in)	SS (Coated) >30 kgf (>66 lbf)	Flap : Diameter 12 mm	Serial no : 6 Barcode : 1D & 2D

PACKAGING

Quantity	Dimensions (mm)	Gross Weight	Standard Colours
300pcs/box	I-33 (L255 x W205 x H145) MTC without wire insertion (wire not yet assemble)	2.3 kg/cm (E) (5.07 lbs)	Body & Body Cap <input type="checkbox"/> TRANSPARENT Twister <input type="checkbox"/> YELLOW Flap A Flap B Cap <input type="checkbox"/> PS.YELLOW <input type="checkbox"/> PS.YELLOW <input type="checkbox"/> WHITE
1000pcs/box	I-43 (L465 x W260 x H190) MTC with wire insertion (wire already twist)	7.7 kg/cm (E) (16.98 lbs)	



FMM EXCELLENCE AWARD 2012
QUEST FOR CONTINUOUS IMPROVEMENT
BEST MANUFACTURER IN MALAYSIA IN 2012

UPDATED : 27 JULY 2020