



This product available in **biodegradable alternatives**.



MEGA FORTRIS
G R O U P

Indicative Seal · Data Sheet

Fort Mini Padlock (FMP)

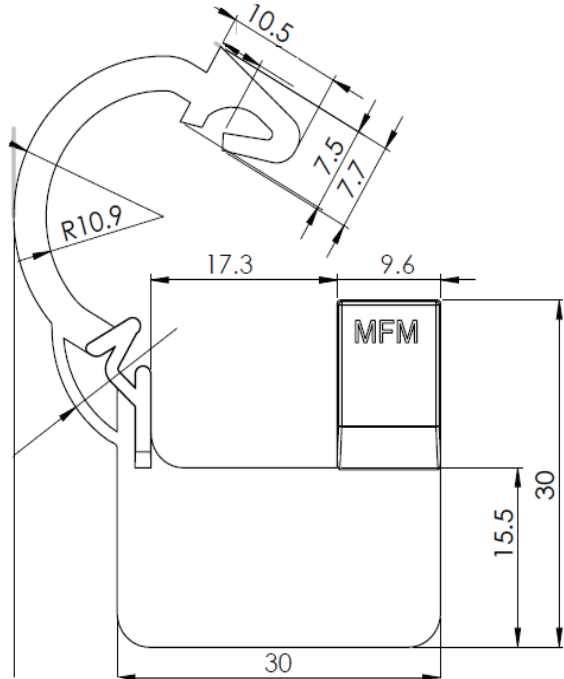

Padlock Seal

Features

- 1 The Fort Mini Padlock is etched with permanent laser marking. Laser marking offers the highest level of security as it cannot be removed or replaced.
- 2 Fort Mini Padlock Easy to apply and remove by hand.
- 3 Fits on many applications because of its slim size.
- 4 Optional- **Biodegradable** additive can be added upon customers' requirement, securing strap gives the user a choice of strength to match different applications.

Technical Specifications

PRODUCT - FORT MINI PADLOCK (FMP)

Product	Material	Locking Space	Strap Dimensions	Tensile Strength	Marking Area	Max Marking Digits
FMP	Body: PP (Option + BIO)	10.5 x 7.7 mm (0.453 x 1.024 in)	17.3 mm (0.681 in)	5 - 9 kgf (11.02 - 213.8 lbf)	11.5 x 26 mm (0.453 x 1.024 in)	Serial no : 8 Barcode no : 8

PACKAGING

	Quantity	Dimensions (mm)	Weight kg	Volume m ³	Standard Colours
Inner Carton	1,000 pcs	330 x 230 x 155 (12.99 x 8.7 x 6.1 in)	0.0012 (0.0012 lbs)	0.02795 (0.987 cu.ft.)	Body

KEY APPLICATIONS

- ✓ Bags
- ✓ Retail Applications
- ✓ Courier
- ✓ Goods-in-transit
- ✓ Postal
- ✓ Banking



FMM EXCELLENCE AWARD 2012
QUEST FOR CONTINUOUS IMPROVEMENT
BEST MANUFACTURER IN MALAYSIA IN 2012

UPDATED : 17 JULY 2020